

MARK	REVISION	CHAR.	APPD.	DATE	REV.

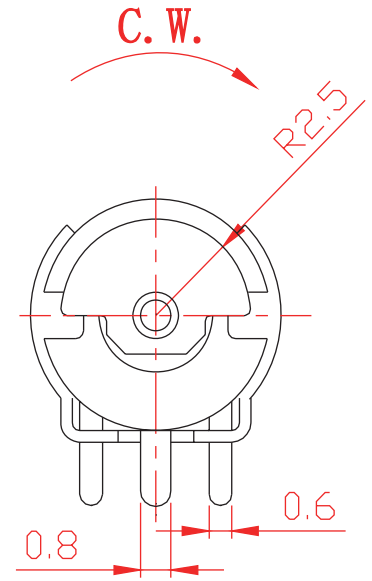
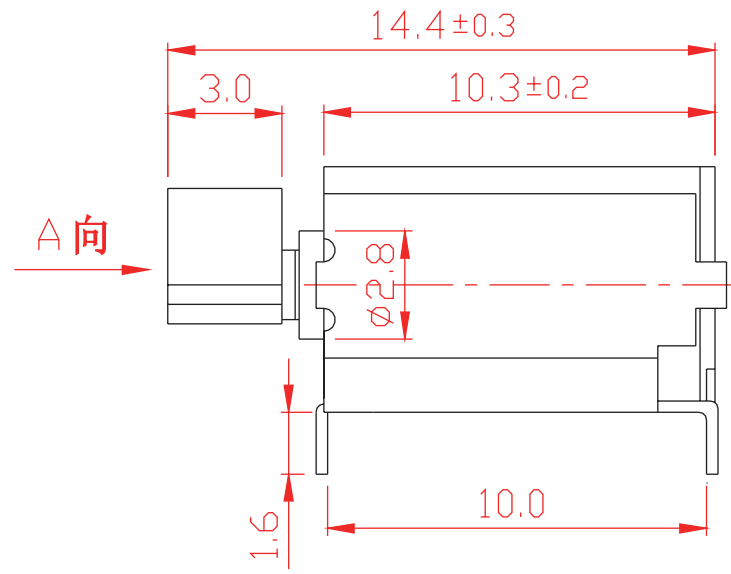
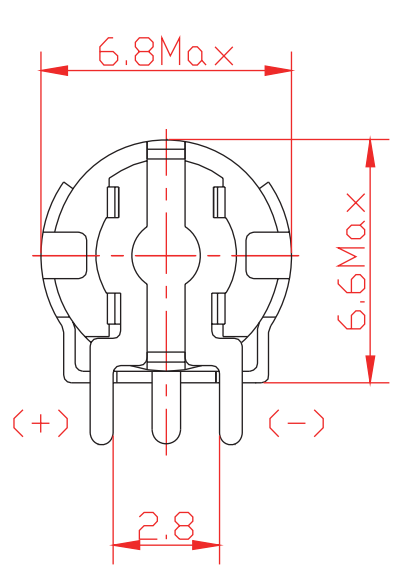

電機特性/Technical Requirements  
 額定電壓/Rated voltage: 3.0V  
 額定電流/Rated current: 70 mA Max  
 額定轉速/Rated speed: 11,000±2,500 rpm  
 堵轉電流/Stall current: 105 mA Max  
 端子阻抗/Terminal resistance: 35Ω ±20%  
 未註線性公差為/Unmarked tolerance: ±0.2mm

Tolerances					Excellent Competent Smart Pro 翰德凱電子有限公司				
Angel	±1/2°	±1°	±1°	±1°	Title 品名	6mm Micro DC DIP type Vibration Motor			
0-10	±0.05	±0.1	±0.2	±0.3	Part No. 料號	EMO-BVC061100D-30KA		Material 材料	
10-50	±0.1	±0.15	±0.3	±0.4	Drawn by 製圖	Ken Cheng	Date 日期	Jul-31-17	Finish 表面處理
50-150	±0.2	±0.25	±0.4	±0.5	Checked by 審圖	Sam Huang	Date 日期	Jul-31-17	Rev. 版本
150-500	±0.3	±0.4	±0.8	±1	Size 圖紙大小	A4	Unit 單位	mm	
>500	±0.5	±0.8	±1	±1.2	Sheet 頁次	1 / 1	Scale 比例	1.000	